

TK5510 WIRING DIAGRAM

(F2WB-1)

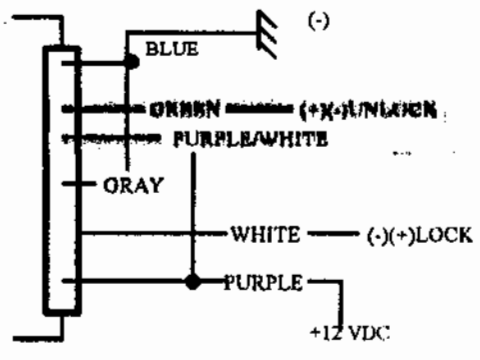
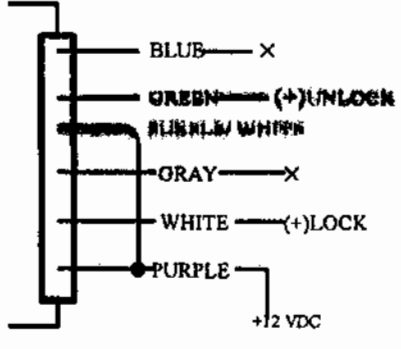
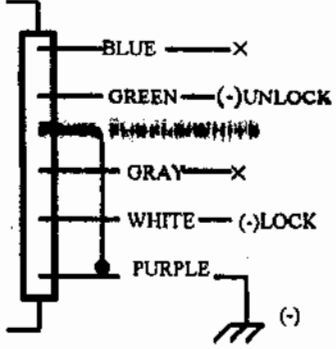
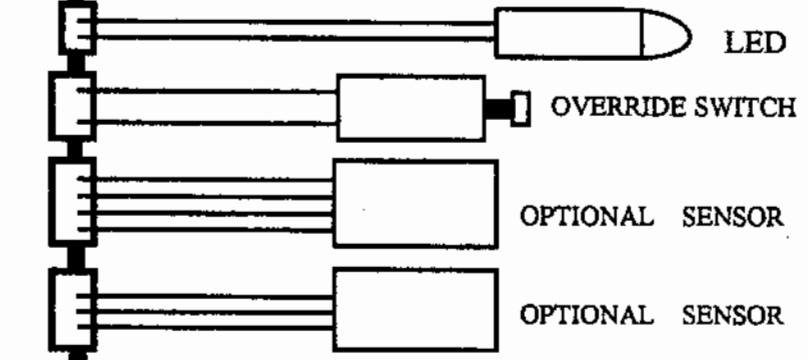
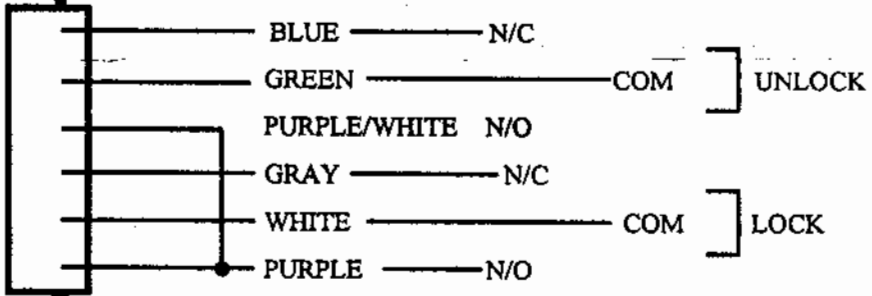
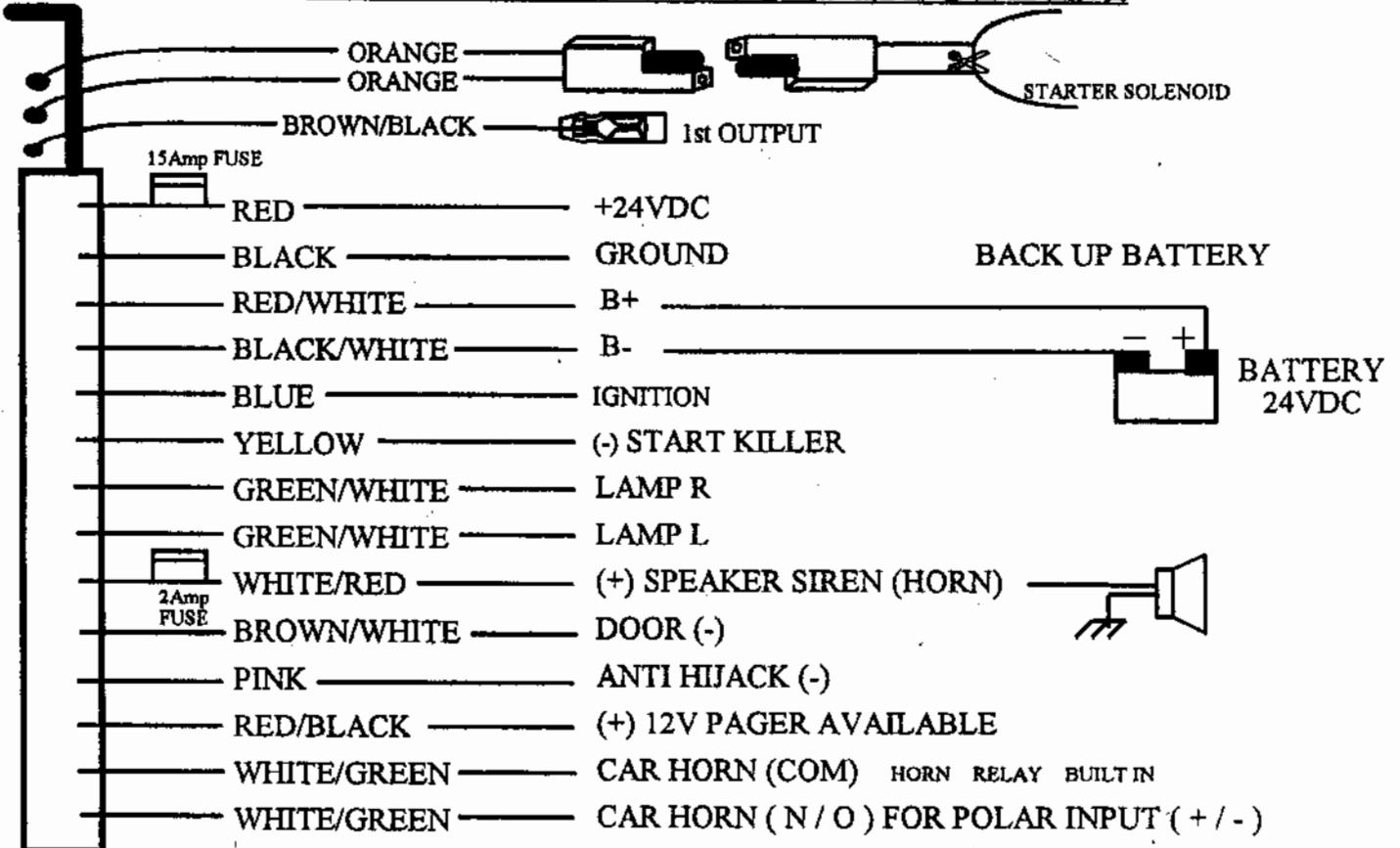

TK5510A OPERATIONAL MANUAL

N2	NORMAL CODE
N8	HOPPING
N0	NEW HOPPING

(K2MB1)

BUTTON ① : A. Arm ——— press again to disarm
 B. Keep press 2" ——— panic (press again to off)
 C. When ignition on ——— door lock/unlock

BUTTON ② : A. Remote 1st aux. output
 B. When arming ——— keep press 2" to car finder
 C. When ignition on ——— keep press 2" to anti-car jacking

BUTTON ① + ② : A. Chirp defeat arm / Chirp defeat disarm
 B. When arming within 5" ——— keep press 2" to shock sensor bypass
 C. When ignition on within 5" ——— keep press 2" to valet mode
 (Repeat normal procedure return to normal function)

@ Button ① + ② press within 5 seconds during arming , parking lights flash 3 times, shock sensor temporary no function until disarm & arm again (become normal again)

W/JUMPER	WITH LAST DOOR ARMING FEATURE
OPEN	CANCEL LAST DOOR ARMING FEATURE
W/JUMPER	DOOR LOCK DURING LAST DOOR ARMING
OPEN	WITHOUT DOOR LOCK DURING LAST DOOR ARMING
W/JUMPER	FOR NORMAL CAR, DOOR SENSOR ALERT WHEN ARM
OPEN	FOR DOME LIGHT DELAY CAR, DOOR SENSOR DELAY ALERT UNTIL DOME LIGHT OFF

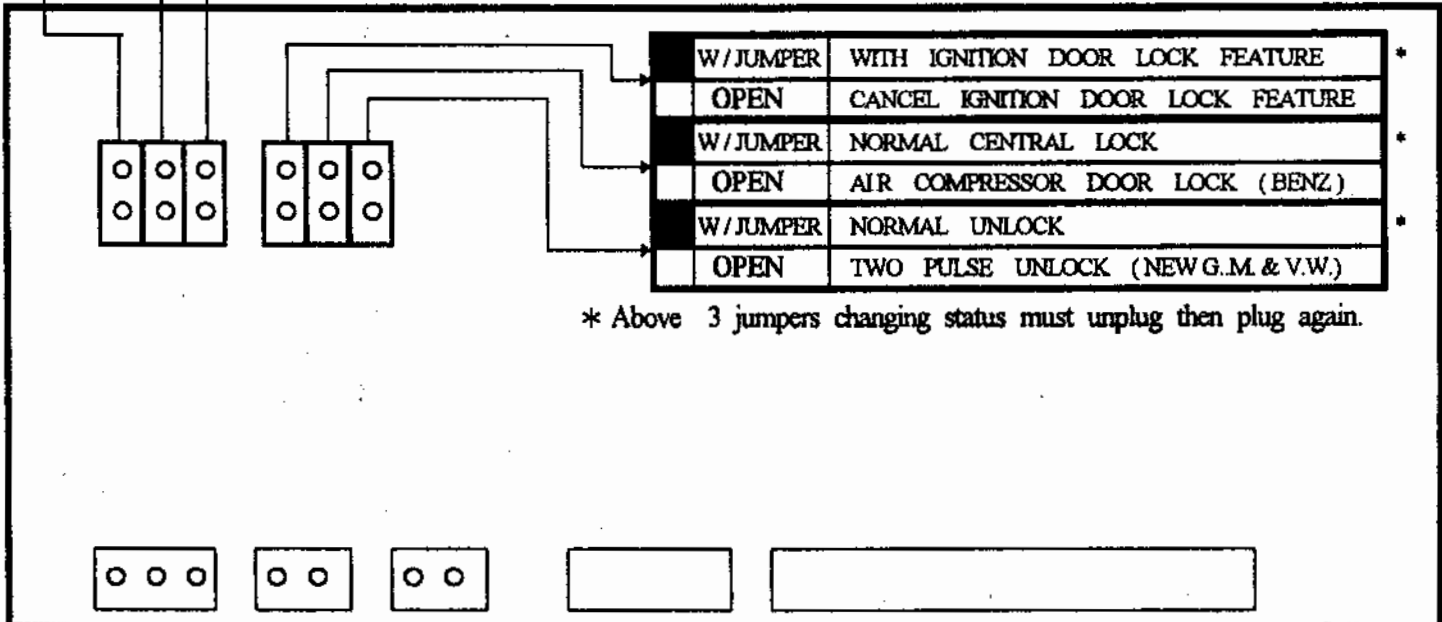

* Above 3 jumpers changing status must unplug then plug again.

FUNCTION PROGRAMMABLE